

## **Modulation of Bile Acid Metabolism by $1\alpha$ -Hydroxyvitamin D<sub>3</sub> Administration in**

### **Mice**

Shigeru Nishida, Jun Ozeki, and Makoto Makishima

Division of Biochemistry, Department of Biomedical Sciences, Nihon University School

of Medicine, 30-1 Oyaguchi-kamicho, Itabashi-ku, Tokyo 173-8610, Japan

Running title: Modulation of bile acid metabolism by vitamin D<sub>3</sub>

Address correspondence to: Makoto Makishima, Division of Biochemistry, Department  
of Biomedical Sciences, Nihon University School of Medicine, 30-1 Oyaguchi-kamicho,  
Itabashi-ku, Tokyo 173-8610, Japan. Fax: +81-3-3972-8199. E-mail:  
maxima@med.nihon-u.ac.jp

Number of pages: 43

Tables: 3

Figures: 9

References: 32

Abstract: 224

Introduction: 493

Discussion: 997

Abbreviations: CA, cholic acid; CDCA, chenodeoxycholic acid; DCA, deoxycholic acid;

LCA, lithocholic acid; FXR, farnesoid X receptor; PXR, pregnane X receptor; VDR, vitamin D receptor;  $1,25(\text{OH})_2\text{D}_3$ ,  $1\alpha,25$ -dihydroxyvitamin  $\text{D}_3$ ; Cyp, cytochrome P450; Asbt, apical sodium-dependent bile acid transporter; MRP, multidrug resistance-associated protein;  $1\alpha(\text{OH})\text{D}_3$ ,  $1\alpha$ -hydroxyvitamin  $\text{D}_3$ ; HDCA, hyodeoxycholic acid; UDCA, ursodeoxycholic acid; MCA, muricholic acid; GC-MS, gas chromatography-mass spectrometry; Ntcp, sodium taurocholate-cotransporting polypeptide; Oatp, organic anion transporting polypeptides; Bsep, bile salt export pump; Ost, organic solute transporter.

## Abstract

The vitamin D receptor (VDR) is a nuclear receptor for the active form of vitamin D<sub>3</sub> and mediates regulation of calcium homeostasis. Bile acids, such as lithocholic acid, have been identified as additional endogenous VDR ligands. The *in vivo* role of VDR in bile acid metabolism has not been elucidated. We investigated potential effects of *in vivo* VDR activation on bile acid metabolism by feeding mice bile acid-supplemented chow and then treating with 1 $\alpha$ -hydroxyvitamin D<sub>3</sub> [1 $\alpha$ (OH)D<sub>3</sub>]. We administered 1 $\alpha$ (OH)D<sub>3</sub> via gavage to mice fed chow supplemented with 0.4% cholic acid (CA), chenodeoxycholic acid (CDCA), deoxycholic acid (DCA), or lithocholic acid (LCA) and examined liver and plasma bile acid composition with gas chromatography-mass spectrometry analysis. 1 $\alpha$ (OH)D<sub>3</sub> treatment reduced hepatic bile acids in mice fed CDCA- and DCA-supplemented chow, but was less effective in mice fed chow supplemented with LCA or CA. 1 $\alpha$ (OH)D<sub>3</sub> administration also decreased plasma bile acids in mice fed bile acids, such as DCA. The effect of 1 $\alpha$ (OH)D<sub>3</sub> administration in decreasing liver bile acid composition was observed in mice under fasting conditions and was associated with increased urinary excretion and increased expression of bile acid

transporters, such as renal multidrug resistance-associated protein 4. These findings indicate that pharmacological activation of VDR enhances metabolism of bile acids, especially urinary excretion. The results confirm that VDR acts a regulator of bile acid metabolism *in vivo*.

## **Introduction**

Bile acids are essential detergents required for the digestion and intestinal absorption of hydrophobic nutrients, such as fatty acids, cholesterol and lipid-soluble vitamins, including vitamin D (Hofmann, 1999). Bile acids are the major products of cholesterol metabolism and play an important role in the elimination of cholesterol by inducing biliary lipid secretion and the solubilization of cholesterol in bile. Primary bile acids, such as cholic acid (CA) and chenodeoxycholic acid (CDCA), are generated from cholesterol by the sequential actions of liver enzymes, and are secreted in bile as glycine or taurine conjugates (Russell, 2003). After assisting in lipid digestion and absorption, most bile acids are reabsorbed in the intestine and recirculate to the liver through a mechanism called the enterohepatic circulation. Bile acids that escape reabsorption are converted to secondary bile acids, such as deoxycholic acid (DCA) and lithocholic acid (LCA), by the intestinal microflora (Ridlon et al., 2006). Bile acids are cytotoxic at elevated concentrations, and secondary bile acids are considered to be involved in the pathogenesis of gallstone disease and colon cancer.

Bile acid metabolism is regulated at several levels, including gene transcription,

RNA translation and protein stability (Russell, 2003). Bile acids act as steroid hormone-like regulatory signals for nuclear receptors, which regulate the expression of genes involved in bile acid synthesis and transport (Makishima, 2005). The farnesoid X receptor (FXR; NR1H4) binds to primary and secondary bile acids, represses bile acid synthesis and hepatocellular import, stimulates bile acid export from cells, and protects hepatocytes from bile acid toxicity. The pregnane X receptor (PXR; NR1I2) senses toxic secondary bile acids and induces their elimination through a xenobiotic metabolism pathway. The vitamin D receptor (VDR; NR1I1), a receptor for  $1\alpha,25$ -dihydroxyvitamin  $D_3$  [ $1,25(OH)_2D_3$ , calcitriol], also acts as a bile acid receptor with specificity for the secondary bile acid LCA and its derivatives (Makishima et al., 2002). While the roles of VDR in calcium and bone homeostasis have been investigated for decades, an understanding of the biology of VDR regulation of bile acid metabolism is only now emerging. VDR induces the intestinal expression of mouse cytochrome P450 3a11 (Cyp3a11) and human CYP3A4 (Thummel et al., 2001; Matsubara et al., 2008). CYP3A enzymes are predominantly expressed in the liver and intestinal mucosa and catalyze the metabolic conversion of a wide diversity of xenobiotics and endogenous substrates,

including bile acids, to more polar derivatives (Xie and Evans, 2001). Dehydroepiandrosterone sulfotransferase 2A1, apical sodium-dependent bile acid transporter (Asbt) and multidrug resistance-associated protein 3 (MRP3) have been demonstrated to be VDR target genes in mouse and human cells (Echchgadda et al., 2004; McCarthy et al., 2005; Chen et al., 2006). Although these proteins are involved in bile acid metabolism, the *in vivo* role of VDR in bile acid metabolism has not been elucidated. In this study, we examined the effects of  $1\alpha$ -hydroxyvitamin D<sub>3</sub> [ $1\alpha(\text{OH})\text{D}_3$ , alfacalcidol] on bile acid composition in mice fed bile acid-supplemented chow and found that VDR activation stimulates metabolism of bile acids such as CDCA.



## Materials and Methods

**Compounds.**  $1\alpha(\text{OH})\text{D}_3$  was kindly provided by Dr. Yoji Tachibana (Nisshin Flour Milling Co., Saitama, Japan). CA, DCA, CDCA, LCA, hyodeoxycholic acid (HDCA) and ursodeoxycholic acid (UDCA) were purchased from Sigma-Aldrich (St. Louis, MO), and  $\alpha$ -muricholic acid ( $\alpha$ -MCA),  $\beta$ -MCA and  $\omega$ -MCA were from Steraloids, Inc. (Newport, RI). [ $1\text{-}^{14}\text{C}$ ]-Glycocholic acid (50 mCi/mmol) was purchased from GE Healthcare (Chalfont St. Giles, United Kingdom).

**Animals and Treatment.** C57BL/6J male mice (5-6 weeks of age; Tokyo Laboratory Animals Science Co., Tokyo, Japan) were housed under controlled temperature ( $23 \pm 1^\circ\text{C}$ ), humidity (45-65%), and standard 12-hour light/12-hour dark cycle. Prior to feeding of chow supplemented with bile acid, mice were fed standard rodent chow (Lab. Animal Diet MF; Oriental Yeast Co., Tokyo, Japan). For bile acid supplementation, standard chow was finely powdered and mixed thoroughly with CA, CDCA, DCA, or LCA at 0.4% (w/w) composition. In initial experiments, mice were fed powdered standard or 0.4% bile acid-supplemented chow for 8 days (Fig. 1A). On days 6,

7 and 8, mice were orally administered  $1\alpha(\text{OH})\text{D}_3$  dissolved in corn oil (0.2 mL) at a dose of 2.5 nmol/mouse per day (n=5-8). At day 9, mice were anesthetized with ether and blood was collected by cardiac puncture with a heparinized syringe. Tissue samples were collected, frozen on dry ice immediately after removal and weighing, and then stored at  $-80^\circ\text{C}$ . In the second experiment, mice were fed chow or 0.4% CDCA-supplemented chow from day 1 until day 5, fasted from day 6, and administered 2.5 nmol/mouse  $1\alpha(\text{OH})\text{D}_3$  via gavage on days 6 and 7 (Fig. 1B). Forty-eight-hour urine samples (on days 7-8) were collected in glass metabolic bowls. The experimental protocol adhered to the Guidelines for Animal Experiments of the Nihon University School of Medicine and was approved by the Ethics Review Committee for Animal Experimentation of Nihon University School of Medicine.

**Extraction and Derivatization of Bile Acids.** For extraction of bile acids, liver samples (about 0.4 g) were homogenized in 6 mL of 80% (v/v) ethanol with a Polytron homogenizer (Kinematica AG, Littau-Lucerne, Switzerland) on ice and centrifuged at  $9,400 \times g$  for 10 min. Precipitates were re-homogenized with 6 mL of 80%

(v/v) ethanol with a Sonifier (Branson, Danbury, CT) and then centrifuged. Extraction with ethanol was repeated three times and combined supernatant from liver homogenate was evaporated to dryness. [1-<sup>14</sup>C]-Glycocholic acid was added to a liver sample and the extraction yield was measured by liquid scintillation counting. The recovery yield of [1-<sup>14</sup>C]-glycocholic acid was 94% (mean from triplicate assay). Plasma bile acids were extracted by solid phase extraction using a C18 Bond Elute column (Varian, Inc., Palo Alto, CA) as reported previously (Setchell and Worthington, 1982). Plasma samples (0.4 mL) were mixed with 1 mL of 0.5 mol/L triethylammonium sulfate, pH 7.5, and heated at 65°C for 15 min to liberate the protein-bound bile acids. After chilling, the mixture was applied to a C18 column, rinsed briefly, eluted with 4 mL of ethanol, and evaporated to dryness. Using a C18 Bond Elute column, quantitative yield is successful attained for both non-polar, such as lithocholic acid, and polar bile acids, including conjugated bile acids (Setchell and Worthington, 1982). We estimated the recovery yield of plasma bile acids from a C18 Bond Elute column using [1-<sup>14</sup>C]-glycocholic acid. Over 98% of [1-<sup>14</sup>C]-glycocholic acid was obtained in the ethanol solution by liquid scintillation counting.

Extracted liver and plasma bile acids were subjected to gas chromatography-mass spectrometry (GC-MS) after derivatization. After the addition of an internal standard, bile acids were treated with 0.6 mL of acetone/methanol/6M HCl (36:4:0.4 by volume) at 37°C for 14 hours to remove the conjugated sulfonyl group (Parmentier and Eyssen, 1975), and then with 15% (w/v) NaOH at 120°C for 2 hours in an autoclave to deconjugate the taurine or glycine moiety (Keller and Jahreis, 2004). Samples were then extracted with 2 mL of hexane twice to remove cholesterol, and then acidified to approximately pH 1 with 2M HCl. Deconjugated bile acids were extracted with 2 mL of diethyl ether three times and converted to methyl esters with trimethylsilyldiazomethane (GL Sciences, Inc. Japan, Tokyo, Japan) and to trimethylsilyl derivatives with *N,O*-bis(trimethylsilyl)trifluoroacetamide plus trimethylchlorosilane (Thermo Fisher Scientific Inc., Rockford, IL).

**GC-MS Analysis of Bile Acids.** We utilized a GC-MS analyzer, Shimadzu GC-MS QP5050A, equipped with an autoinjector AOC-20i and a data system, GCMS Solution (Shimadzu Corporation, Kyoto, Japan). Gas-chromatographic separation was

carried out with a separation column of HP-5 (cross linked 5% Ph-Me silicon, 0.32 mm internal diameter, 0.15  $\mu\text{m}$  film thickness and 25 m in length; Agilent Technologies, Inc., Santa Clara CA). The injection temperature was 150°C and the column temperature was programmed at 150°C for 5 minutes, 10°C /minute to 260°C and held for 30 minutes. An ionizing energy was set at 70 eV, an ionizing trap current at 60  $\mu\text{A}$ , and an ion detector gain at 1.1 kV. Highly purified helium gas was used as carrier gas at a flow rate of 1.0 ml/minute. Split ratio was 1:10, and sampling rate was 0.5 seconds. The bile acids were analyzed as methylester-trimethylsilyl derivatives (Setchell et al., 1983). An appropriate fragment ion in the high mass region was selected for mass fragmentography. Their fragment ions (m/z) and relative intensities (%) were as follows: LCA (target ion, m/z 372,100%; reference ions, 215, 149% and 257, 51%), DCA (target ion, 255,100%; reference ions, 208, 20% and 370, 13%), CDCA (target ion, 370,100%; reference ions, 255, 31% and 355, 25%), CA (target ion, 253,100%; reference ions, 368, 60% and 458, 35%), HDCA (target ion, 370,100%; reference ions, 255, 72% and 355, 32%), UDCA (target ion, 460,100%; reference ions, 370, 42% and 255, 41%),  $\alpha$ -MCA (target ion, 458,100%; reference ions, 443, 25% and 195, 28%),  $\beta$ -MCA (target ion, 195,100%;

reference ions, 285, 68% and 458, 9%), and  $\omega$ -MCA (target ion, 195,100%; reference ions, 285, 58% and 369, 29%). Total bile acid concentrations were calculated from summation of individual bile acid concentrations.

### **Concentrations of Plasma Calcium, Aminotransferases, and Urinary Total**

**Bile Acid.** Plasma total calcium levels, alanine and aspartate aminotransferases, urinary total bile acid concentrations, and urinary and plasma creatinine concentrations were measured using Calcium C-Testwako, Transaminase CII-Testwako, Total bile acid-Testwako, and Creatinine Testwako (Wako Pure Chemical Industries, Osaka, Japan), respectively. Urinary bile acid concentrations were normalized with creatinine levels.

**Immunoblotting.** Kidney membrane preparation was performed as reported previously (Zollner et al., 2006b). Proteins in the membrane fraction were resolved by 7.5% sodium dodecyl sulfate-polyacrylamide gel electrophoresis, transferred to nitrocellulose membrane (Bio-Rad Laboratories, Inc., Hercules, CA) and probed with a monoclonal antibody against Mrp4 (Santa Cruz Biotechnology, Inc., Santa Cruz, CA), or

an anti-lamin B antibody (Santa Cruz Biotechnology) to confirm the equal protein amount in the lanes. Although Mrp4 has a predicted molecular weight of 150 kDa, it has a number of potential transmembrane regions, glycosylation and phosphorylation sites, which may affect the migration of the protein (Zollner et al., 2006b). Homogenized protein was quantified with a BCA protein assay kit (Thermo Fisher Scientific Inc., Rockford, IL).

#### **Real-Time Quantitative Reverse-Transcription Polymerase Chain**

**Reaction.** Total RNAs from samples were prepared by the acid guanidine thiocyanate-phenol/chloroform method and cDNAs were synthesized using the ImProm-II Reverse Transcription system (Promega Corporation, Madison, WI) (Ogura et al., 2009). Real-time polymerase chain reaction was performed on the ABI PRISM 7000 Sequence Detection System (Applied Biosystems, Foster City, CA) using SYBR Green PCR Master Mix (Applied Biosystems). Primers for Mrp3 (GenBank accession number NM\_029600) were 5'-GCC AAC TTC CTC CGA AAC TA-3' and 5'-CTT GCG GAC CTC GTA GAT GG-3', and others have been reported previously (Ishizawa et al., 2008;

Ogura et al., 2009). Relative mRNA levels were calculated by the comparative threshold cycle method using glyceraldehyde-3-phosphate dehydrogenase as the internal control (Choi et al., 2006).

**Statistical Analysis.** Data are presented as means  $\pm$  SD, and statistical differences were determined by ANOVA.



## Results

### Modulation of Bile Acid Compositions in Liver and Plasma of Mice fed

**Bile Acid-Supplemented Chow by  $1\alpha(\text{OH})\text{D}_3$ .** We fed mice with chow supplemented with 0.4% bile acid for 6 days and examined the effects of bile acid supplements on food intake and liver toxicity in mice. Feeding with CA, DCA and LCA slightly decreased the food intake, but did not induce a significant increase in plasma aminotransferase levels (Table 1). CDCA feeding did not change food intake or plasma aminotransferase levels. Thus, 0.4% bile acid supplements have no or only modest toxic effects in mice. To examine the effects of VDR activation on bile acid metabolism, we fed mice with control chow or chow supplemented with 0.4% bile acid and then administered  $1\alpha(\text{OH})\text{D}_3$  via gavage as shown in Fig.1A.  $1\alpha(\text{OH})\text{D}_3$  is rapidly converted to  $1,25(\text{OH})_2\text{D}_3$  after injection and is more effective than  $1,25(\text{OH})_2\text{D}_3$  in prolonging survival time of mice inoculated with leukemia cells (Honma et al., 1983). Treatment of mice with  $1\alpha(\text{OH})\text{D}_3$  for 3 days increased plasma calcium levels to 18.5 mg/dL from 10.3 mg/dL of control mice, consistent with effective VDR activation (Table 2). We examined plasma and liver bile acid composition with GC-MS after deconjugation. In mice fed control chow diet,

CA (22%) and  $\omega$ -MCA (56%) were the major hepatic bile acids (Fig. 2A). CA and  $\beta$ -MCA have been reported to be the major hepatic bile acids in mice (Stedman et al., 2004; Zollner et al., 2006b). Since  $\omega$ -MCA is a secondary bile acid converted from  $\beta$ -MCA by intestinal bacteria (Eyssen et al., 1983), microflora may influence the concentration of  $\omega$ -MCA in the bile acid pool.  $1\alpha(\text{OH})\text{D}_3$  treatment decreased the minor bile acid components (LCA, DCA, HDCA, UDCA, CDCA), but did not change total bile acid, CA, or  $\omega$ -MCA concentrations. CA, HDCA, UDCA and DCA were detected in plasma, and  $1\alpha(\text{OH})\text{D}_3$  decreased plasma total bile acid and DCA concentrations (Fig. 2B).

We examined the effects of  $1\alpha(\text{OH})\text{D}_3$  on bile acid metabolism by feeding mice 0.4% bile acid-supplemented chow as shown in Fig. 1A. First, we fed mice chow supplemented with primary bile acids. CDCA feeding increased the total bile acid concentrations in liver and plasma 2.8-fold and 2.4-fold, respectively, compared with those in mice fed control chow (Figs. 2 and 3). The major bile acid components in the liver of CDCA-fed mice were  $\alpha$ -MCA (35%), UDCA (21%),  $\omega$ -MCA (17%), and CDCA (17%) (Fig. 3A). CDCA is converted to  $\alpha$ -MCA and  $\beta$ -MCA in the liver and to UDCA by

microflora (Botham and Boyd, 1983; Fromm et al., 1983).  $1\alpha(\text{OH})\text{D}_3$  treatment decreased total bile acid concentration, LCA, DCA, HDCA, UDCA, CDCA,  $\beta$ -MCA, and  $\omega$ -MCA in the liver. CDCA feeding increased plasma CDCA and  $\alpha$ -MCA (Fig. 3B). Due to high variation for other bile acids, only the  $1\alpha(\text{OH})\text{D}_3$ -dependent decrease in DCA was statistically significant. CA feeding increased liver total bile acids 2.2-fold compared with mice fed control chow and 89% of the liver bile acids were CA (Fig. 4A). Plasma total bile acids were increased in mice fed CA 11-fold compared with mice fed control chow (Figs. 2 and 4), and CA and DCA were the major pool components (Fig. 4B).  $1\alpha(\text{OH})\text{D}_3$  treatment decreased plasma total bile acids and CA, but did not reduce hepatic bile acids.

Next, we examined the effects of  $1\alpha(\text{OH})\text{D}_3$  on mice fed chow supplemented with secondary bile acids. DCA feeding increased total liver bile acids 4.3-fold compared with mice fed control chow (Figs. 2 and 5). The liver of these mice contained CA (72%) and DCA (27%), and  $1\alpha(\text{OH})\text{D}_3$  treatment effectively decreased hepatic total bile acids, DCA and CA (Fig. 5A). Total plasma bile acids were increased 18-fold compared with mice fed control chow, and  $1\alpha(\text{OH})\text{D}_3$  treatment decreased plasma total bile acids (Fig.

5B). Although the effect of  $1\alpha(\text{OH})\text{D}_3$  on plasma DCA was not significant ( $p = 0.06$ ), the  $1\alpha(\text{OH})\text{D}_3$ -induced decrease in the total bile acid concentration in mice fed DCA could be due to enhanced metabolism or elimination of DCA. LCA feeding did not increase the total bile acid concentration of liver or plasma (Figs. 2 and 6). In the liver of mice fed LCA the major bile acids were HDCA (24%) and  $\alpha$ -MCA (32%) (Fig. 6A). LCA is metabolized to HDCA by CYP3A enzymes, which are induced by LCA-responsive nuclear receptors, such as PXR and VDR (Xie et al., 2001; Makishima et al., 2002).  $1\alpha(\text{OH})\text{D}_3$  treatment decreased LCA and DCA, but had no effect on total bile acids, HDCA and  $\alpha$ -MCA in the liver of LCA-fed mice.  $1\alpha(\text{OH})\text{D}_3$  did not alter plasma bile acid levels (Fig. 6B). Therefore,  $1\alpha(\text{OH})\text{D}_3$  administration enhances the metabolism of bile acids, such as CDCA and DCA.

### **Bile Acid Metabolism is Enhanced by $1\alpha(\text{OH})\text{D}_3$ Treatment in Fasted**

**Mice Pre-Fed CDCA-Supplemented Chow.**  $1\alpha(\text{OH})\text{D}_3$  treatment induces hypercalcemia and weight loss in mice (Ishizawa et al., 2008). To rule out the possibility that hypercalcemia-associated decreased food intake affects liver and plasma bile acid

concentrations, we fed mice chow supplemented with or without CDCA for 5 days and then administered  $1\alpha(\text{OH})\text{D}_3$  under fasting condition (Fig. 1B). Body weight did not differ between vehicle-treated mice and  $1\alpha(\text{OH})\text{D}_3$ -treated mice (Table 3). In mice fed normal chow, 2-day fasting decreased liver bile acid concentrations (Figs. 2 and 7). The major bile acids were CA and  $\omega$ -MCA, similar to the pool composition in mice fed control chow *ad lib*. Interestingly, the total bile acid concentration in the liver of mice pre-fed CDCA-supplemented chow decreased to control levels after 2 days of fasting, and  $1\alpha(\text{OH})\text{D}_3$  administration further decreased the total hepatic bile acids (Fig. 7A and B). CDCA pre-feeding decreased CA and  $\omega$ -MCA and increased UDCA, CDCA and  $\alpha$ -MCA in the liver, and  $1\alpha(\text{OH})\text{D}_3$  administration decreased bile acids, such as CA and UDCA (Fig. 7B). Although not statistically significant due to high variation,  $1\alpha(\text{OH})\text{D}_3$  likely decreased CDCA and  $\alpha$ -MCA. This indicates that the finding of decreased hepatic bile acids by  $1\alpha(\text{OH})\text{D}_3$  is not due to a secondary effect of decreased food intake.  $1\alpha(\text{OH})\text{D}_3$  treatment also likely decreased plasma DCA, CA and UDCA in mice pre-fed CDCA, although these effects were not statistically significant (Fig. 7C). We examined total bile acid concentration in urine and found that  $1\alpha(\text{OH})\text{D}_3$  administration increased urinary

excretion of bile acids, especially in mice pre-fed CDCA-supplemented chow (Fig. 7D).

These findings suggest that VDR activation stimulates the excretion of bile acids via urine.

### **1 $\alpha$ (OH)D<sub>3</sub> Treatment Induces Expression of Bile Acid Transporters.** We

examined mRNA expression of genes involved in bile acid metabolism in mice treated with 1 $\alpha$ (OH)D<sub>3</sub>. In the liver, bile acids are synthesized from cholesterol by enzymes, such as cholesterol 7 $\alpha$ -hydroxylase (Cyp7a1) and sterol 12 $\alpha$ -hydroxylase (Cyp8b1), and are catabolized by detoxifying enzymes, such as CYP3A (Xie and Evans, 2001; Russell, 2003). Sodium taurocholate-cotransporting polypeptide (Ntcp) and organic anion transporting polypeptides (Oatps) are involved in bile acid uptake at the basolateral membrane of hepatocytes, and bile acids are excreted by the canalicular bile salt export pump (Bsep) and Mrp2 (Zollner et al., 2006a). At hepatocyte basolateral membrane, Mrp3, Mrp4, and the organic solute transporter  $\alpha/\beta$  (Ost $\alpha/\beta$ ) play a role in alternative expression of bile acids into the system circulation. 1 $\alpha$ (OH)D<sub>3</sub> treatment increased liver mRNA expression of Cyp7a1 and Ost $\alpha$ , although it was not effective on expression of

Cyp24a1, a VDR target gene involved in vitamin D inactivation (Fig. 8A). Expression of enzymes (Cyp8b1 and Cyp3a11) and transporters (Ntcp, Oapt1a1, Oatp1a4, Oatp1b2, Bsep, Mrp2, Mrp3, Mrp4, and Ost $\beta$ ) was not significantly changed (data not shown). Since VDR does not induce transcription of a target gene in hepatocytes because of low expression of VDR (Gascon-Barre et al., 2003), the effect of 1 $\alpha$ (OH)D<sub>3</sub> treatment on Cyp7a1 and Ost $\alpha$  expression may be through indirect mechanisms. As reported previously (Ishizawa et al., 2008; Ogura et al., 2009), 1 $\alpha$ (OH)D<sub>3</sub> induced mRNA expression of Cyp24a1 in the kidney and small intestine (Fig. 8B and C), indicating that 1 $\alpha$ (OH)D<sub>3</sub> treatment effectively activates VDR in these tissues. The bile acid transporters Mrp2, Mrp4, and Ost $\alpha$ / $\beta$  are expressed in renal tubular cells and are thought to be involved in urinary bile acid excretion (Zollner et al., 2006a). 1 $\alpha$ (OH)D<sub>3</sub> increased renal mRNA expression of Mrp2, Mrp3, and Mrp4 (Fig. 8B), but not Ost $\alpha$  or Ost $\beta$  (data not shown). Asbt, Mrp3, and Ost $\alpha$ / $\beta$  are suggested to be involved in bile acid transport in enterocytes (Zollner et al., 2006a). Treatment of mice with 1 $\alpha$ (OH)D<sub>3</sub> increased intestinal mRNA expression of Asbt and Mrp4 (Fig. 8C), but not Mrp2, Mrp3, Ost $\alpha$ , or Ost $\beta$  (data not shown).

Since  $1\alpha(\text{OH})\text{D}_3$  administration increased urinary excretion of bile acids (Fig. 7D) and renal mRNA expression of bile acid transporters (Fig. 8B), we examined protein expression of renal bile acid transporters. Immunoblotting analysis showed increased renal expression of Mrp4 protein in mice treated with  $1\alpha(\text{OH})\text{D}_3$  (Fig. 8D). These findings indicate that VDR activation stimulates bile acid excretion through increased bile acid transporter expression in kidney.



## Discussion

In this study, we report that  $1\alpha(\text{OH})\text{D}_3$  treatment enhances bile acid metabolism *in vivo*. A bile acid-supplemented diet increased liver bile acid concentrations, indicating that bile acids absorbed from the intestine accumulate in the liver. In the liver of mice fed CDCA, DCA, and LCA, the major bile acids detected in the liver were  $\alpha$ -MCA (Fig. 3A), CA (Fig. 5A), and  $\alpha$ -MCA (Fig. 6A), respectively. Alternatively, CA was the major bile acid in the liver of mice fed CA (Fig. 4A). These findings indicate that supplemented CDCA, DCA and LCA are metabolized effectively but CA is resistant to metabolism. CA and  $\beta$ -MCA have been reported to be major hepatic bile acids in mice (Stedman et al., 2004; Zollner et al., 2006b), and  $\alpha$ -MCA is thought to be a precursor of  $\beta$ -MCA (Cherayil et al., 1963) (Fig. 9). Hepatic bile acids from the enterohepatic circulation may be subjected to conversion to primary bile acids, CA and  $\alpha$ -MCA, although a detailed mechanism of bile acid metabolism in rodents remains to be elucidated.  $1\alpha(\text{OH})\text{D}_3$  treatment decreased several bile acid components in the liver of mice fed normal chow (Fig. 2A), and this effect was observed more clearly in mice fed CDCA (Fig. 3A). Similar effects of  $1\alpha(\text{OH})\text{D}_3$  on hepatic bile acid compositions were

observed in mice administered  $1\alpha(\text{OH})\text{D}_3$  under fasting condition (Fig. 7B). Compared to the decrease in hepatic bile acids, such as CDCA, UDCA and  $\omega$ -MCA, in  $1\alpha(\text{OH})\text{D}_3$ -treated mice, we did not detect increased bile acid components. These findings suggest that  $1\alpha(\text{OH})\text{D}_3$  treatment stimulates bile acid metabolism, particularly enhancing transport for excretion. Bile acids are excreted from hepatocytes into bile ducts by Bsep and Mrp2 (Zollner et al., 2006a) (Fig. 9). At the hepatocyte basolateral membrane, Mrp3, Mrp4, and Ost $\alpha/\beta$  play a role in the alternative excretion of bile acids into the systemic circulation.  $1\alpha(\text{OH})\text{D}_3$  treatment increased mRNA expression of Cyp7a1 and Ost $\alpha$  in the liver (Fig. 8A). Cyp7a1 catalyzes the rate-limiting step of the classical bile acid synthesis pathway and is negatively regulated by the bile acid receptor FXR (Makishima, 2005). The induction of Cyp7a1 may be due to a decrease in FXR-activating bile acids by excretion from hepatocytes. The bile acid transporters Mrp2, Mrp4, and Ost $\alpha/\beta$  are thought to be involved in urinary bile acid excretion (Zollner et al., 2006a; Alrefai and Gill, 2007). Although the role of Mrp3 in the renal bile acid transport has not been elucidated, Mrp3 is a direct target gene of VDR (McCarthy et al., 2005).  $1\alpha(\text{OH})\text{D}_3$  treatment increased mRNA expression of kidney Mrp2, Mrp3, and Mrp4 (Fig.

8B). We also observed increased protein expression of kidney Mrp4 (Fig. 8D) and increased urinary excretion of bile acids in mice treated with  $1\alpha(\text{OH})\text{D}_3$  (Fig. 7D). These findings suggest that  $1\alpha(\text{OH})\text{D}_3$  treatment decreases hepatic bile acids by inducing bile acid transporters for urinary excretion (Fig. 9).

In DCA-fed mice,  $1\alpha(\text{OH})\text{D}_3$  treatment decreased hepatic DCA effectively but was less effective in altering CA concentration (Fig. 5A).  $1\alpha(\text{OH})\text{D}_3$  treatment was not effective in reducing accumulated CA in the liver of mice fed CA (Fig. 4A). VDR-induced mechanisms may be ineffective in elimination of accumulated CA in the liver. In contrast to hepatic CA, the plasma CA concentration was decreased after  $1\alpha(\text{OH})\text{D}_3$  treatment in mice fed CA (Fig. 4B). Plasma bile acid levels were also increased in mice fed DCA (Fig. 5B), but not in mice fed CDCA (Fig. 3B) or LCA (Fig. 6B). Increased plasma CA and DCA may be regulated by VDR-induced excretion into urine. Although LCA is an endogenous ligand for VDR (Makishima et al., 2002),  $1\alpha(\text{OH})\text{D}_3$  administration was not effective in decreasing bile acid concentrations in mice fed LCA (Fig. 6A). Although hepatic LCA and DCA were decreased by  $1\alpha(\text{OH})\text{D}_3$  treatment, accumulated HDCA and  $\alpha$ -MCA were not affected. HDCA and  $\alpha$ -MCA may

be products of LCA metabolism by LCA-activated VDR and VDR-induced mechanisms may not be effective in the further elimination of HDCA and  $\alpha$ -MCA.

Bile acids are essential detergents that are required for the ingestion and intestinal absorption of hydrophobic nutrients, including vitamin D (Hofmann, 1999). VDR has dual functions as an endocrine receptor for  $1,25(\text{OH})_2\text{D}_3$  and as a metabolic sensor for secondary bile acids, such as lithocholic acid (Makishima et al., 2002). Although several genes involved in bile acid metabolism, such as CYP3A4 and MRP3, have been reported to be VDR target genes (McCarthy et al., 2005; Matsubara et al., 2008), the *in vivo* role of VDR as a bile acid sensor may be limited. While administration of high concentrations of LCA restored serum calcium levels to the normal range in vitamin D-deficient rats by increasing VDR target gene expression and bone calcium mobilization, it was not effective in rats with normal vitamin D levels (Nehring et al., 2007). These findings indicate that LCA can substitute for vitamin D in calcium homeostasis only in vitamin D-deficient rats. We demonstrated in this study that pharmacological doses of vitamin D enhance bile acid metabolism.  $1,25(\text{OH})_2\text{D}_3$  increases plasma bile clearance of vitamin  $\text{D}_3$  and  $1,25(\text{OH})_2\text{D}_3$  (Gascon-Barre and

Gamache, 1991). While hepatocytes express low levels of VDR, biliary epithelial cells express functional VDR (Gascon-Barre et al., 2003). VDR activation in biliary epithelial cells may influence biliary excretion of bile acids as well as vitamin D compounds. In addition, the extracellular calcium-sensing receptor is expressed in hepatocytes and its activation enhances bile flow (Canaff et al., 2001). Increased blood calcium by vitamin D administration may also influence bile acid elimination.  $1\alpha(\text{OH})\text{D}_3$  administration is not effective in altering bile acids accumulated in bile duct-ligated mice (Ogura et al., 2009). This may be due to artificial obstruction of bile flow. About 20 enzymes have been shown to be involved in bile acid synthesis in the liver (Russell, 2003). The mechanisms of catabolism and transport of bile acids in the liver and kidney remain to be elucidated. The investigation of vitamin D-regulated bile acid metabolism will be helpful for understanding bile acid metabolism, especially elimination, and in the prevention and treatment of bile acid-associated diseases.

## **Acknowledgements**

The authors thank Dr. Choi Mihwa, Dr. Michitaka Ogura, Dr. Sachiko Yamada, and other members of the Makishima laboratory for technical assistance and helpful comments, Dr. Toshiyuki Sakaki of Toyama Prefectural University for helpful comments, Mr. Masao Shimamura for assistance in GC-MS analysis, and Dr. Andrew I. Shulman for editing assistance.

## References

- Alrefai W and Gill R (2007) Bile acid transporters: structure, function, regulation and pathophysiological implications. *Pharm Res* **24**:1803-1823.
- Botham KM and Boyd GS (1983) The metabolism of chenodeoxycholic acid to beta-muricholic acid in rat liver. *Eur J Biochem* **134**:191-196.
- Canaff L, Petit J-L, Kisiel M, Watson PH, Gascon-Barre M, and Hendy GN (2001) Extracellular calcium-sensing receptor is expressed in rat hepatocytes. coupling to intracellular calcium mobilization and stimulation of bile flow. *J Biol Chem* **276**:4070-4079.
- Chen X, Chen F, Liu S, Glaeser H, Dawson PA, Hofmann AF, Kim RB, Shneider BL, and Pang KS (2006) Transactivation of rat apical sodium-dependent bile acid transporter and increased bile acid transport by  $1\alpha,25$ -dihydroxyvitamin D<sub>3</sub> via the vitamin D receptor. *Mol Pharmacol* **69**:1913-1923.
- Cherayil GD, Hsia SL, Matschiner JT, Doisy EA, Jr., Elliott WH, Thayer SA, and Doisy EA (1963) Bile acids. XVII. Metabolism of  $\alpha$ -muricholic acid-24-C-14 in the rat. *J Biol Chem* **238**:1973-1978.

Choi M, Moschetta A, Bookout AL, Peng L, Umetani M, Holmstrom SR, Suino-Powell

K, Xu HE, Richardson JA, Gerard RD, Mangelsdorf DJ, and Kliewer SA (2006)

Identification of a hormonal basis for gallbladder filling. *Nat Med* **12**:1253-1255.

Echchgadda I, Song CS, Roy AK, and Chatterjee B (2004) Dehydroepiandrosterone

sulfotransferase is a target for transcriptional induction by the vitamin D receptor.

*Mol Pharmacol* **65**:720-729.

Eyssen H, De Pauw G, Stragier J, and Verhulst A (1983) Cooperative formation of

omega-muricholic acid by intestinal microorganisms. *Appl Environ Microbiol*

**45**:141-147.

Fromm H, Sarva RP, and Bazzoli F (1983) Formation of ursodeoxycholic acid from

chenodeoxycholic acid in the human colon: studies of the role of 7-ketolithocholic

acid as an intermediate. *J Lipid Res* **24**:841-853.

Gascon-Barre M, Demers C, Mirshahi A, Neron S, Zalzal S, and Nanci A (2003) The

normal liver harbors the vitamin D nuclear receptor in nonparenchymal and

biliary epithelial cells. *Hepatology* **37**:1034-1042.

Gascon-Barre M and Gamache M (1991) Contribution of the biliary pathway to the



homeostasis of vitamin D<sub>3</sub> and of 1,25-dihydroxyvitamin D<sub>3</sub>. *Endocrinology* **129**:2335-2344.

Hofmann AF (1999) The continuing importance of bile acids in liver and intestinal disease. *Arch Intern Med* **159**:2647-2658.

Honma Y, Hozumi M, Abe E, Konno K, Fukushima M, Hata S, Nishii Y, DeLuca HF, and Suda T (1983) 1 $\alpha$ ,25-Dihydroxyvitamin D<sub>3</sub> and 1 $\alpha$ -hydroxyvitamin D<sub>3</sub> prolong survival time of mice inoculated with myeloid leukemia cells. *Proc Natl Acad Sci U S A* **80**:201-204.

Ishizawa M, Matsunawa M, Adachi R, Uno S, Ikeda K, Masuno H, Shimizu M, Iwasaki K, Yamada S, and Makishima M (2008) Lithocholic acid derivatives act as selective vitamin D receptor modulators without inducing hypercalcemia. *J Lipid Res* **49**:763-772.

Keller S and Jahreis G (2004) Determination of underivatized sterols and bile acid trimethyl silyl ether methyl esters by gas chromatography-mass spectrometry-single ion monitoring in faeces. *J Chromatogr B Analyt Technol Biomed Life Sci* **813**:199-207.

Makishima M (2005) Nuclear receptors as targets for drug development: regulation of cholesterol and bile acid metabolism by nuclear receptors. *J Pharmacol Sci* **97**:177-183.

Makishima M, Lu TT, Xie W, Whitfield GK, Domoto H, Evans RM, Haussler MR, and Mangelsdorf DJ (2002) Vitamin D receptor as an intestinal bile acid sensor. *Science* **296**:1313-1316.

Matsubara T, Yoshinari K, Aoyama K, Sugawara M, Sekiya Y, Nagata K, and Yamazoe Y (2008) Role of vitamin D receptor in the lithocholic acid-mediated CYP3A induction in vitro and in vivo. *Drug Metab Dispos* **36**:2058-2063.

McCarthy TC, Li X, and Sinal CJ (2005) Vitamin D receptor-dependent regulation of colon multidrug resistance-associated protein 3 gene expression by bile acids. *J Biol Chem* **280**:23232-23242.

Nehring JA, Zierold C, and DeLuca HF (2007) Lithocholic acid can carry out in vivo functions of vitamin D. *Proc Natl Acad Sci U S A* **104**:10006-10009.

Ogura M, Nishida S, Ishizawa M, Sakurai K, Shimizu M, Matsuo S, Amano S, Uno S, and Makishima M (2009) Vitamin D<sub>3</sub> modulates the expression of bile acid

regulatory genes and represses inflammation in bile duct-ligated mice. *J*

*Pharmacol Exp Ther* **328**:564-570.

Parmentier G and Eyssen H (1975) Synthesis of the specific monosulfates of cholic acid.

*Steroids* **26**:721-729.

Ridlon JM, Kang D-J, and Hylemon PB (2006) Bile salt biotransformations by human

intestinal bacteria. *J Lipid Res* **47**:241-259.

Russell DW (2003) The enzymes, regulation, and genetics of bile acid synthesis. *Annu*

*Rev Biochem* **72**:137-174.

Setchell KD, Lawson AM, Tanida N, and Sjovall J (1983) General methods for the

analysis of metabolic profiles of bile acids and related compounds in feces. *J*

*Lipid Res* **24**:1085-1100.

Setchell KDR and Worthington J (1982) A rapid method for the quantitative extraction of

bile acids and their conjugates from serum using commercially available

reverse-phase octadecylsilane bonded silica cartridges. *Clinica Chimica Acta*

**125**:135-144.

Stedman C, Robertson G, Coulter S, and Liddle C (2004) Feed-forward regulation of bile

acid detoxification by CYP3A4: studies in humanized transgenic mice. *J Biol Chem* **279**:11336-11343.

Thummel KE, Brimer C, Yasuda K, Thottassery J, Senn T, Lin Y, Ishizuka H, Kharasch E, Schuetz J, and Schuetz E (2001) Transcriptional control of intestinal cytochrome P-4503A by 1 $\alpha$ ,25-dihydroxy vitamin D<sub>3</sub>. *Mol Pharmacol* **60**:1399-1406.

Xie W and Evans RM (2001) Orphan nuclear receptors: the exotics of xenobiotics. *J Biol Chem* **276**:37739-37742.

Xie W, Radomska-Pandya A, Shi Y, Simon CM, Nelson MC, Ong ES, Waxman DJ, and Evans RM (2001) An essential role for nuclear receptors SXR/PXR in detoxification of cholestatic bile acids. *Proc Natl Acad Sci U S A* **98**:3375-3380.

Zollner G, Marschall HU, Wagner M, and Trauner M (2006a) Role of nuclear receptors in the adaptive response to bile acids and cholestasis: pathogenetic and therapeutic considerations. *Mol Pharm* **3**:231-251.

Zollner G, Wagner M, Moustafa T, Fickert P, Silbert D, Gumhold J, Fuchsbichler A, Halilbasic E, Denk H, Marschall H-U, and Trauner M (2006b) Coordinated induction of bile acid detoxification and alternative elimination in mice: role of

FXR-regulated organic solute transporter- $\alpha/\beta$  in the adaptive response to bile acids. *Am J Physiol Gastrointest Liver Physiol* **290**:G923-932.

### **Footnote**

This work was supported in part by grants from the Ministry of Education, Culture, Sports, Science, and Technology, Japan (Grant-in-Aid for Scientific Research on Priority Areas (No. 18077995)), and Nihon University (Nihon University Joint Research Grant for 2006).

### Figure legends

Fig. 1. Experimental procedure for bile acid feeding and  $1\alpha(\text{OH})\text{D}_3$  treatment in mice.

(A) Mice were fed standard or 0.4% bile acid-supplemented chow for 8 days. Mice were administrated  $1\alpha(\text{OH})\text{D}_3$  via gavage at days 6, 7, and 8, and sacrificed at day 9. (B) Mice were fed standard or 0.4% CDCA-supplemented chow for the first 5 days and were then fasted from day 6.  $1\alpha(\text{OH})\text{D}_3$  was administered to fasted mice on day 6 and 7. Mice were sacrificed for sample collection at day 8.

Fig. 2. Bile acid compositions in liver (A) and plasma (B) in mice fed standard chow.

Mice were fed standard chow and administered  $1\alpha(\text{OH})\text{D}_3$  as shown in Fig.1A. \*,  $p < 0.05$  compared with vehicle control to  $1\alpha(\text{OH})\text{D}_3$  administration. ND, not detected.

Fig. 3. Bile acid compositions in liver (A) and plasma (B) in mice fed

CDCA-supplemented chow. Mice were fed 0.4% CDCA-supplemented chow and administered  $1\alpha(\text{OH})\text{D}_3$  as shown in Fig.1A. \*,  $p < 0.05$ ; \*\*,  $p < 0.01$ ; \*\*\*,  $p < 0.001$  compared with vehicle control to  $1\alpha(\text{OH})\text{D}_3$  administration.

Fig. 4. Bile acid compositions in liver (A) and plasma (B) in mice fed CA-supplemented chow. Mice were fed 0.4% CA-supplemented chow and administered  $1\alpha(\text{OH})\text{D}_3$  as shown in Fig.1A. \*,  $p < 0.05$ ; \*\*,  $p < 0.01$  compared with vehicle control to  $1\alpha(\text{OH})\text{D}_3$  administration. ND, not detected.

Fig. 5. Bile acid compositions in liver (A) and plasma (B) in mice fed DCA-supplemented chow. Mice were fed 0.4% DCA-supplemented chow and administered  $1\alpha(\text{OH})\text{D}_3$  as shown in Fig.1A. \*,  $p < 0.05$ ; \*\*,  $p < 0.01$ ; \*\*\*,  $p < 0.001$  compared with vehicle control to  $1\alpha(\text{OH})\text{D}_3$  administration. ND, not detected.

Fig. 6. Bile acid compositions in liver (A) and plasma (B) in mice fed LCA-supplemented chow. Mice were fed 0.4% LCA-supplemented chow and administered  $1\alpha(\text{OH})\text{D}_3$  as shown in Fig.1A. \*,  $p < 0.05$  compared with vehicle control to  $1\alpha(\text{OH})\text{D}_3$  administration. ND, not detected.



Fig.7. Effects of  $1\alpha(\text{OH})\text{D}_3$  on bile acid composition in mice pre-fed CDCA-supplemented chow. Bile acid compositions in the liver of mice fed standard chow (A) and 0.4% CDCA-supplemented chow (B). (C) Bile acid compositions in plasma in mice fed 0.4 % CDCA-supplemented chow. (D) Total bile acid concentrations in urine. Mice were fasted after feeding and administered  $1\alpha(\text{OH})\text{D}_3$  as shown in Fig. 1B. \*,  $p < 0.05$ ; \*\*,  $p < 0.01$ ; \*\*\*,  $p < 0.001$  compared with vehicle control to  $1\alpha(\text{OH})\text{D}_3$  administration. ND, not detected.

Fig. 8. Effects of  $1\alpha(\text{OH})\text{D}_3$  on mRNA expression of genes involved in bile acid metabolism in liver (A), kidney (B), and intestine (C), and on renal Mrp4 protein expression (D). Total RNA was prepared from the liver, kidney, and small intestine of mice fed standard chow with or without  $1\alpha(\text{OH})\text{D}_3$  treatment as shown in Fig. 1A (n=6/each), and expression of the indicated genes was measured with real-time quantitative polymerase chain reaction using glyceraldehyde-3-phosphate dehydrogenase as the internal control. Values for normalized mRNA expression are relative to those of vehicle control-treated mice. The values represent the means  $\pm$  SD. n.s., not significant; \*,

$p < 0.05$ ; \*\*,  $p < 0.01$ ; \*\*\*,  $p < 0.001$ . Proteins from the kidney were subjected to immunoblotting. Each lane was loaded with 41  $\mu\text{g}$  of membrane proteins. Experiments were repeated with different mouse samples with similar results.

Fig. 9. Model of effects of VDR ligand on bile acid metabolism. Primary bile acids, CA and CDCA, are generated from cholesterol by liver enzymes, including Cyp7a1 and Cyp8b1, and are secreted in bile as glycine or taurine conjugates. CDCA is metabolized to  $\alpha$ -MCA and  $\beta$ -MCA in the rodent liver. Bsep and Mrp2 are localized in the canalicular membrane of hepatocytes and transport bile acids into bile. Most bile acids are reabsorbed in the intestine and recirculate to the liver through the portal vein in a mechanism called the enterohepatic circulation. Bile acids that escape reabsorption are converted to the secondary bile acids DCA, LCA, UDCA, and  $\omega$ -MCA by intestinal microflora. Portions of the secondary bile acids enter the enterohepatic circulation from the colon. The transporters Asbt, Mrp3, Ost $\alpha/\beta$  are involved in bile acid absorption in the intestine. At the basolateral membrane of hepatocytes, Ntcp and Oatps uptake bile acids from the portal circulation. The basolateral transporters Mrp3, Mrp4, and Ost $\alpha/\beta$  play a

role in the alternative excretion of bile acids from hepatocytes into the systemic circulation. Renal Mrp2, Mrp4, Ost $\alpha/\beta$  are thought to be involved in urinary bile acid excretion. VDR activation induces expression of bile acid transporters, such as liver Ost $\alpha$ , kidney Mrp2, and Mrp4, and stimulates urinary excretion of bile acids. Expression of liver Cyp7a1, intestinal Asbt, Mrp4, and renal Mrp3 are also induced by VDR activation. Thus, VDR, which responds to both 1,25(OH) $_2$ D $_3$  and LCA, plays a role in regulation of bile acid metabolism.

TABLE 1

Cumulative food intake and plasma transaminase levels in mice fed bile acid-supplemented chow

Mice were fed 0.4% bile acid-supplemented chow for 6 days (n=5 for each condition). Values represent mean  $\pm$  SD.

Bile acid in diet	Cumulative food intake (g)	Plasma ALT (IU/l)	Plasma AST (IU/l)
Control	16.7 $\pm$ 0.5	10.8 $\pm$ 12.3	42.5 $\pm$ 14.7
CDCA	16.0 $\pm$ 0.5	18.0 $\pm$ 13.6	79.9 $\pm$ 31.9
CA	12.2 $\pm$ 0.9 <i>p</i> < 0.001 <sup>a</sup>	23.1 $\pm$ 5.2	101.5 $\pm$ 14.8
DCA	13.3 $\pm$ 0.9 <i>p</i> < 0.001 <sup>a</sup>	26.3 $\pm$ 9.4	115.7 $\pm$ 50.8
LCA	14.5 $\pm$ 1.4 <i>p</i> < 0.001 <sup>a</sup>	11.5 $\pm$ 2.0	84.6 $\pm$ 16.7

<sup>a</sup>Comparison with control chow.

ALT, alanine aminotransferase; AST, aspartate aminotransferase.

TABLE 2

Body weight and plasma calcium levels in mice fed bile acid-supplemented chow and treated with  $1\alpha(\text{OH})\text{D}_3$ . Mice were fed 0.4% bile acid-supplemented chow and treated with vehicle ( $-1\alpha(\text{OH})\text{D}_3$ ) or  $1\alpha(\text{OH})\text{D}_3$  ( $+1\alpha(\text{OH})\text{D}_3$ ) as shown in Fig.1A. Values for body weight and plasma calcium levels represent mean  $\pm$  SD.

Bile acid in diet	Body weight (g)		Plasma calcium (mg/dL)		Number of mice	
	$-1\alpha(\text{OH})\text{D}_3$	$+1\alpha(\text{OH})\text{D}_3$	$-1\alpha(\text{OH})\text{D}_3$	$+1\alpha(\text{OH})\text{D}_3$	$-1\alpha(\text{OH})\text{D}_3$	$+1\alpha(\text{OH})\text{D}_3$
Control	20.1 $\pm$ 1.6	15.2 $\pm$ 1.3 <i>p</i> < 0.001 <sup>a</sup>	10.3 $\pm$ 1.7	18.5 $\pm$ 2.1 <i>p</i> < 0.001 <sup>a</sup>	5	7
CDCA	22.1 $\pm$ 2.4	20.0 $\pm$ 1.8	11.9 $\pm$ 0.7	15.0 $\pm$ 1.6 <i>p</i> < 0.001 <sup>a</sup>	8	8
CA	22.1 $\pm$ 1.7	19.2 $\pm$ 1.4 <i>p</i> < 0.01 <sup>a</sup>	6.6 $\pm$ 1.1	11.6 $\pm$ 1.2 <i>p</i> < 0.001 <sup>a</sup>	8	8
DCA	20.1 $\pm$ 0.7	14.9 $\pm$ 1.1 <i>p</i> < 0.001 <sup>a</sup>	9.4 $\pm$ 2.8	12.8 $\pm$ 1.7 <i>p</i> < 0.05 <sup>a</sup>	8	8
LCA	22.4 $\pm$ 1.3	19.5 $\pm$ 0.8 <i>p</i> < 0.001 <sup>a</sup>	9.7 $\pm$ 1.3	15.2 $\pm$ 4.4 <i>p</i> < 0.001 <sup>a</sup>	8	7

<sup>a</sup>Comparison with vehicle control without  $1\alpha(\text{OH})\text{D}_3$  treatment.

TABLE 3

Body weight and plasma calcium levels in mice pre-fed bile acid-supplemented chow and treated with  $1\alpha(\text{OH})\text{D}_3$  under fasting. Mice were pre-fed 0.4% CDCA-supplemented chow and treated with vehicle (-  $1\alpha(\text{OH})\text{D}_3$ ) or  $1\alpha(\text{OH})\text{D}_3$  (+  $1\alpha(\text{OH})\text{D}_3$ ) under fasting conditions as shown in Fig. 1B. Values for body weight and plasma calcium levels represent mean  $\pm$  SD.

Bile acid in diet	Body weight (g)		Plasma calcium (mg/dL)		Number of mice	
	- $1\alpha(\text{OH})\text{D}_3$	+ $1\alpha(\text{OH})\text{D}_3$	- $1\alpha(\text{OH})\text{D}_3$	+ $1\alpha(\text{OH})\text{D}_3$	- $1\alpha(\text{OH})\text{D}_3$	+ $1\alpha(\text{OH})\text{D}_3$
Control	20.5 $\pm$ 0.5	20.2 $\pm$ 1.3	6.0 $\pm$ 0.4	6.8 $\pm$ 0.6	5	7
CDCA	20.7 $\pm$ 1.5	20.5 $\pm$ 0.8	7.1 $\pm$ 0.7	7.6 $\pm$ 1.5	6	6

<sup>a</sup>Comparison with vehicle control without  $1\alpha(\text{OH})\text{D}_3$  treatment.

A

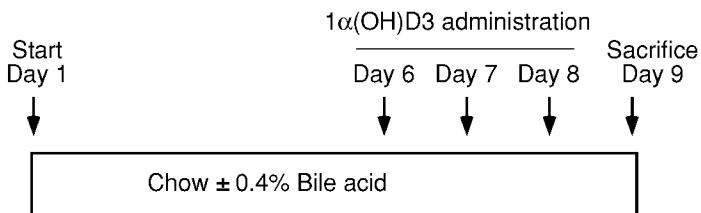

B

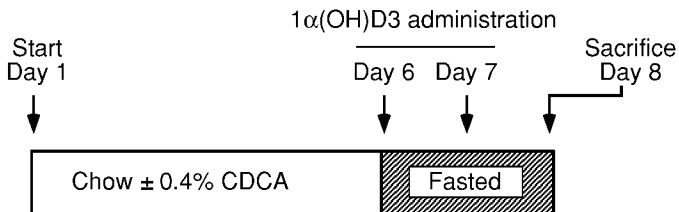

Fig. 1

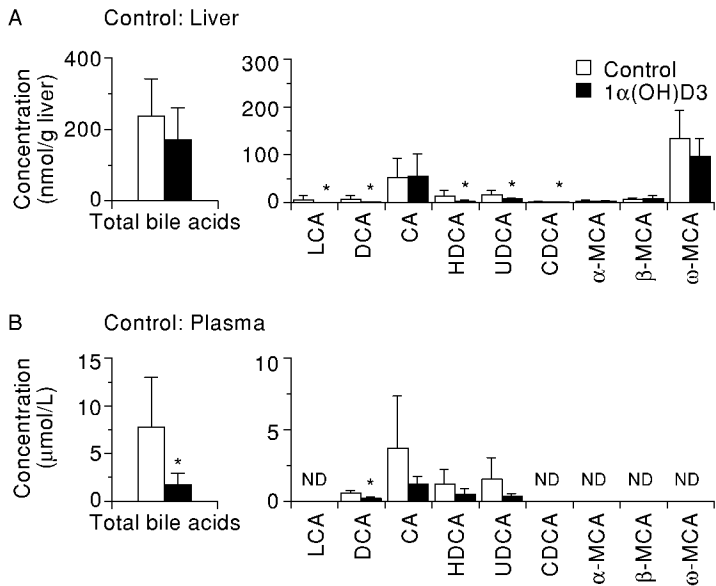

Fig. 2



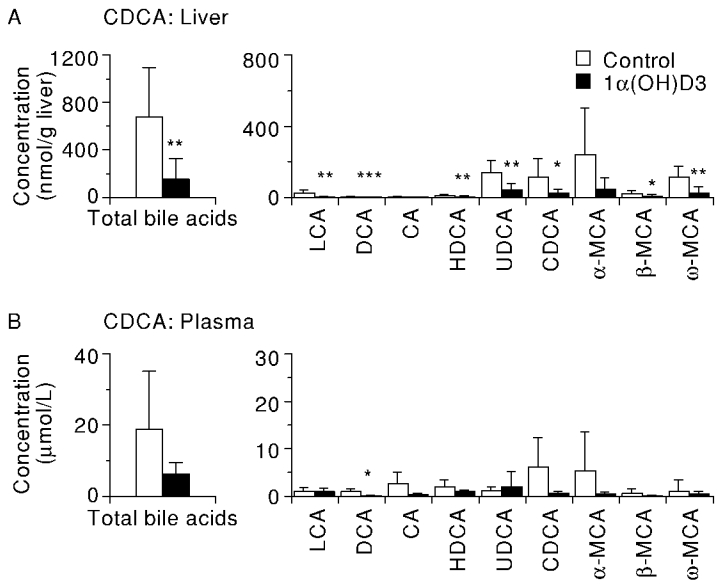

Fig. 3

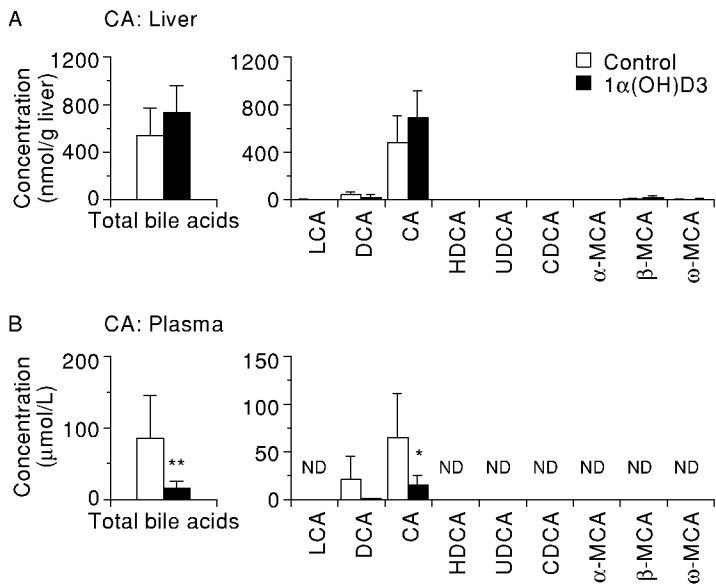

Fig. 4

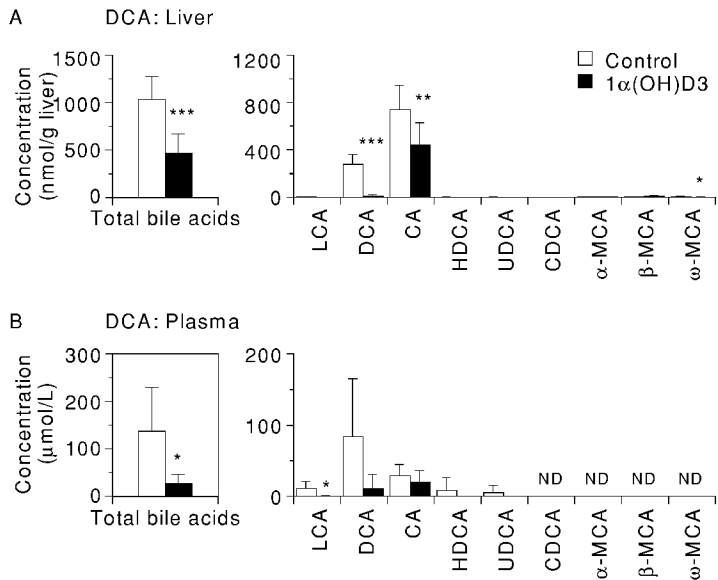

Fig. 5

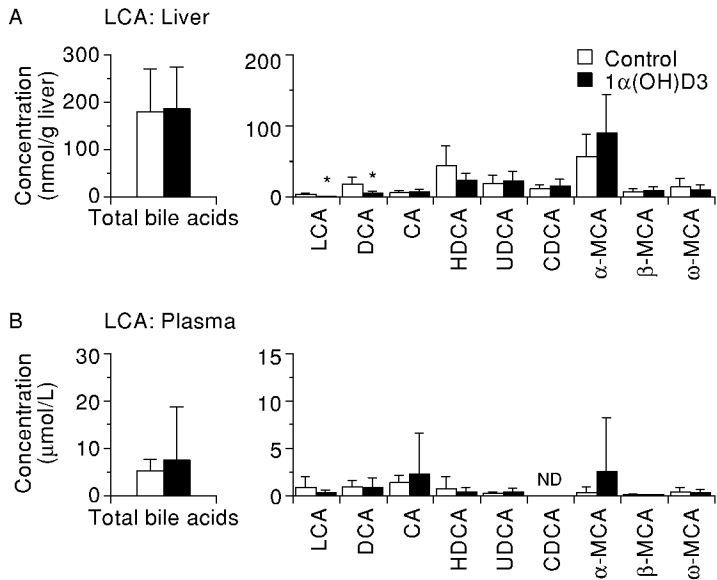

Fig. 6

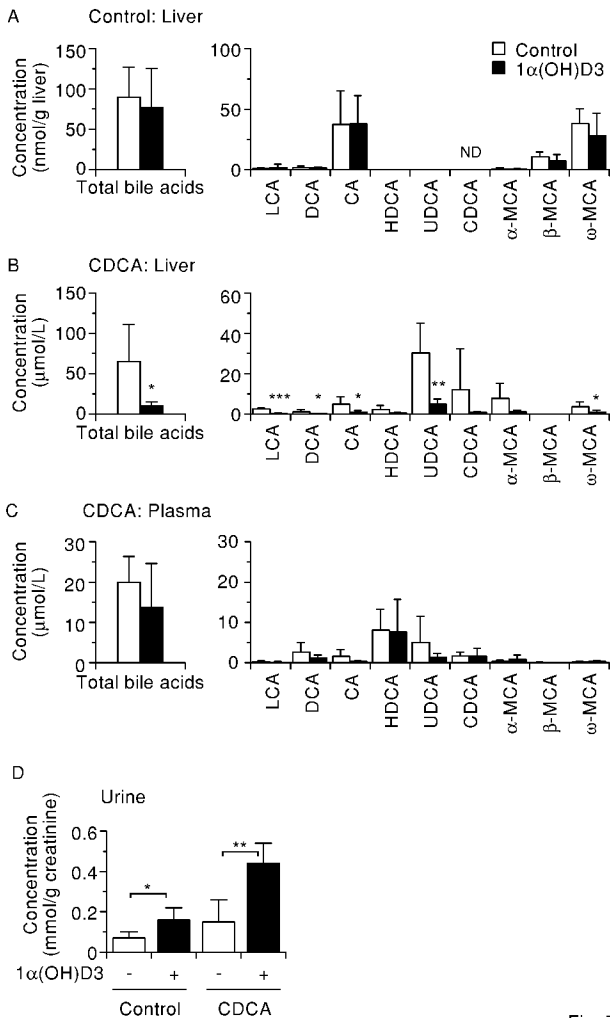
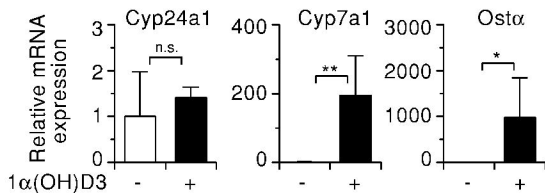
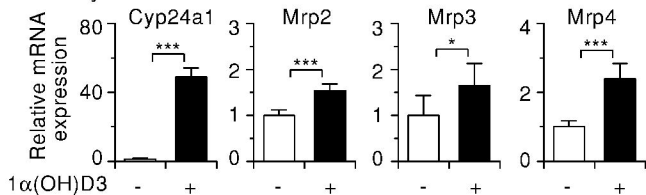

Fig. 7

**A Liver**



**B Kidney**



**C Small Intestine**

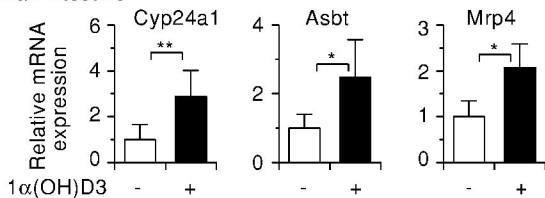

**D**

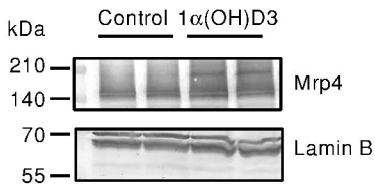

**Fig. 8**

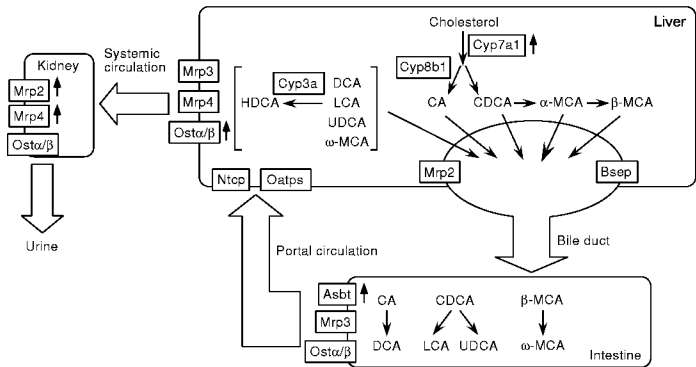

Fig.9